

# EEPC INDIA Technology Centre

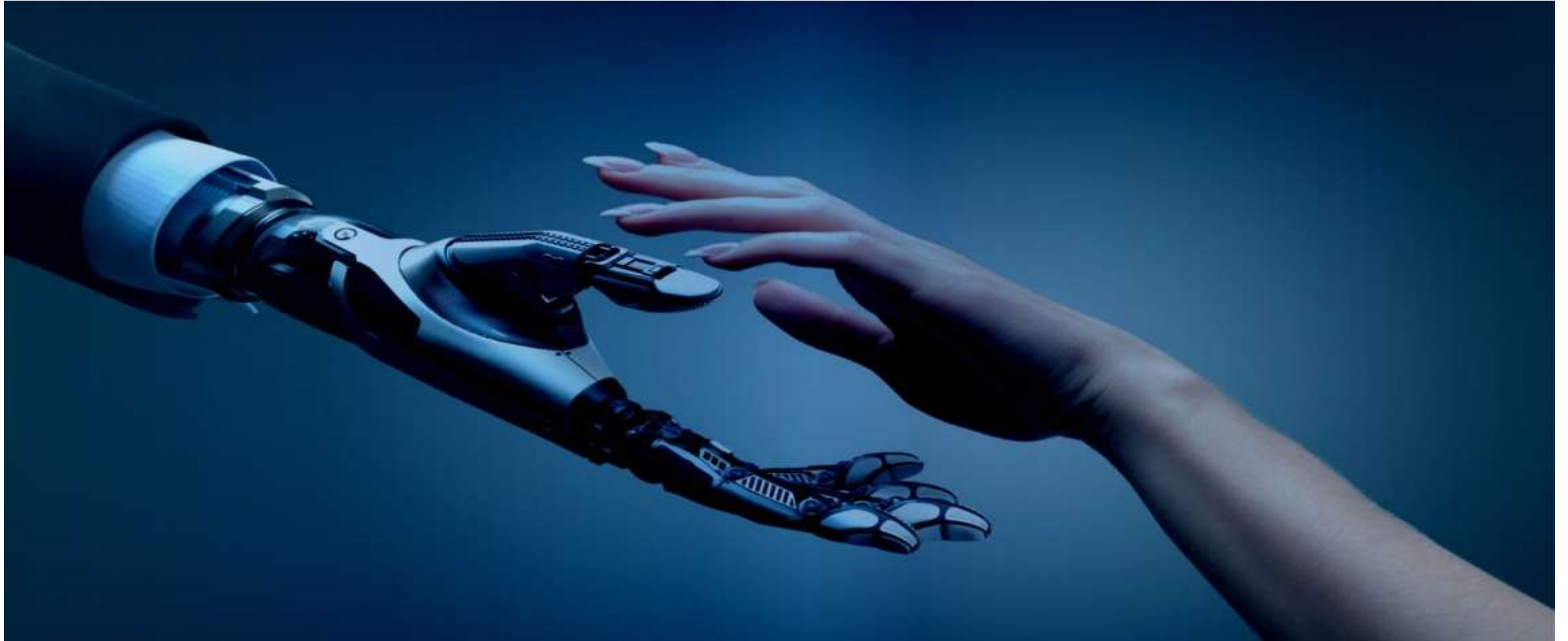

# Technology Centre-Road Map

*Technology Vertical was set up in 2015*

## Core Functions

Promote Trade & Investment

Representation at National,  
Regional & Local Level

Publicity, Branding and  
Publications

Capacity Building

Policy Advocacy

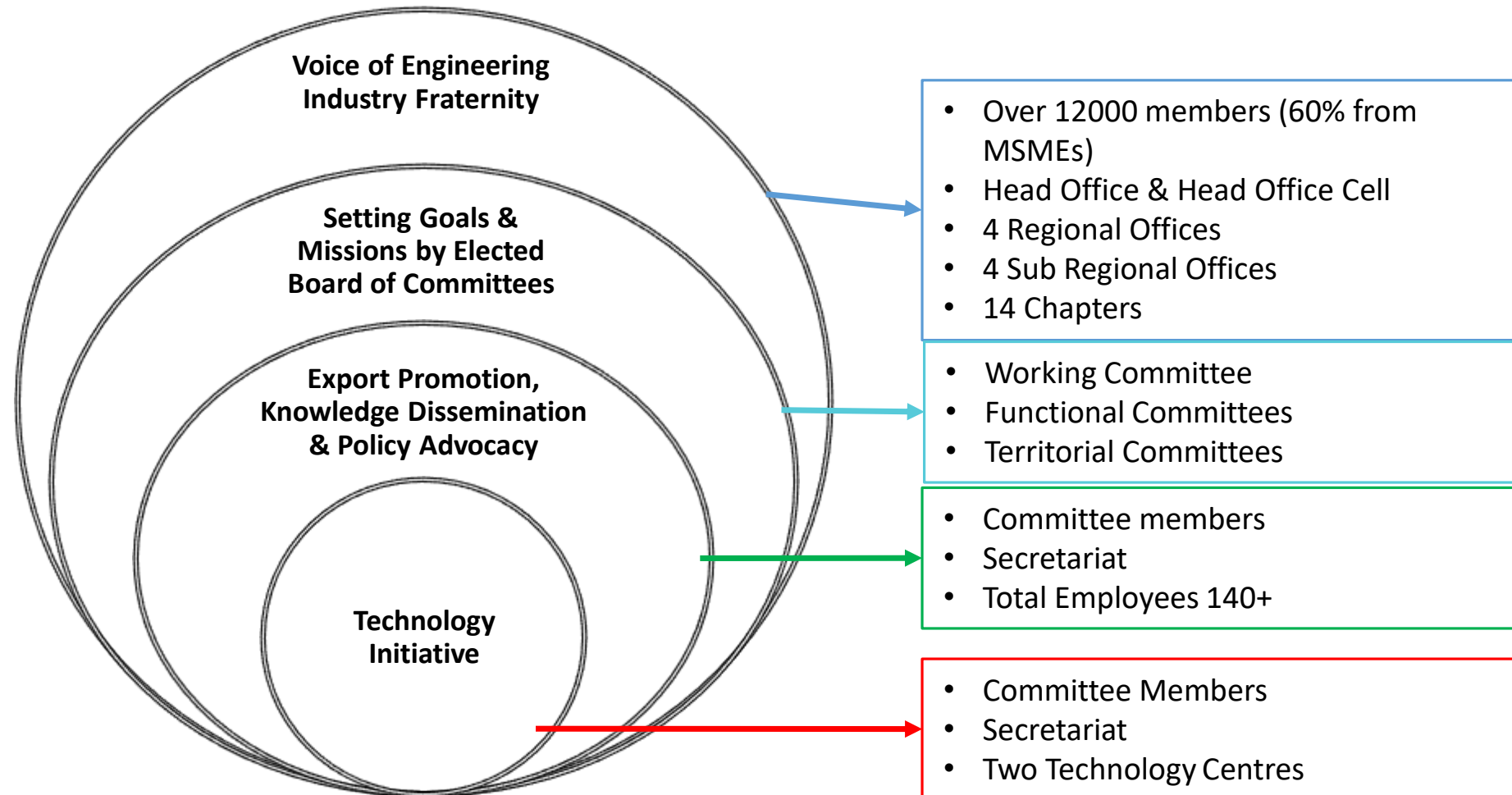

## Offerings through Technology Centres

- **Reverse engineering & Additive Manufacturing Facility at Tech Centre, Kolkata – Capabilities and Capacities.**
- **Training and Seminars:** Best Industry Practices e.g. Six Sigma, Lean manufacturing, 5S house-keeping , Quality control circles, KAIZEN, TPM, etc. and dissemination of technical inputs on latest technology.
- **Advisory and Consultancy services:** - Facilitating Technical troubleshooting, process improvement/development, product development, Re-use through recycling, waste.
- **Testing, Calibration and Inspection:** Facilitate by suitable tie-up with NABL accredited labs across India at concessional rate.
- **Certification of Standards :** viz. ISO , CE marking, etc. by standardize agencies at concessional rate.
- **IPR activities:** Patenting of products, copyrights, assessment and formulating collaborative agreements through its **Intellectual Property Right Cell.**
- **Knowledge and information dissemination** through website [www.techcenter.eepcindia.com](http://www.techcenter.eepcindia.com) , in-house magazine ie2 and Tech Centre E-News Letter.
- **EEPCINDIA students interface :** For Junior Engineers and fresh Engineering students made industry-ready.
- **Tech Centre Membership & Benefits**–Organizational (EEPC and Non-EEPC) and Individual (Technocrats and Students).
- Panel of Technical Subject Experts are available to impart specialized and expertise knowledge, solutions and consultancy through the concept of **“Multi-specialty Techno-clinic”** .
- Implementation of **Energy conservation & Energy Audit** in Engineering Industries in association with TERI, New Delhi.

## 1. Technology Centre: Infrastructure (capacity)



Skill Development Centre – A 60 Seated state-of-art Training/conferencing facility having interactive spark board for web based transmission & excellent acoustic facility.

Industry Connect - Video Conference & Library facility for connecting all centres in India.

Kolkata & Bengaluru Centre :-

3D Modeliining Softwares:

- Creo,Solidworks,SolidCam, Inventor.
- Artec EVA 3D Scanner
- Stratasys/F170 FDM 3D Plastic printers

# 1.Capability

- CAPABILITIES
  - Legacy conversion
  - 3D Parametric modelling
  - Concept Design
  - Detailed Engineering
  - Validation of Assembly design
  - Weight reduction and optimisation
  - Assembly part count reduction and simplification of design
  - design-to-manufacture (DFM)
  - design-for-assembly (DFA)
  - Preparing Bill of Materials
  - Reverse Engineering
  - 3D printing and prototyping
  - New Product Development Studies
  - Tear down and feature analysis
  - Model Based Design(MBD) of parts and assemblies (Paperless drawings)
  - Quality Check of Drawings
  - Training of fresher's on CAD Software



# 1. Reverse Engineering and 3D Printing Projects



## 3D Printing Prototypes

Sl. No.	Project
<b>3D Printing Job.</b>	
1	Cor 45 Deg (Medical equipment) in ABS material
2	Bottle ; b) Cap1; c) Cap2 and d) Lid in ABS Material.
3	Electric insulator part in ABS material
4.	Gears, Joints, Piping Products, Structures, Sculptures, Tools and fixtures, Small Gearbox, Pullies and others.

## 3D Modelling and Drafting support

<b>3D Modelling and Drawing Job.</b>	
Sl. No.	Job Assignments
1	Ni-Hard Block Assembly 3D Modelling & Drawing
2	Mud Guns
3	Piston Rod Assembly
4	3D Modelling and drawing of Valve seat and Bracket
5	3D Modelling and drawing of 18"X 5" grate
6	3D Modelling and drawing of 958.8*958.8mm Cover and frame of Sanitary casting
7	745mm Dia Cover with Frame
8	624mm Dia Frame and cover
9	950mm OD Cover with Frame

# 1. 3D Printing Projects

Sl. No.	Project	Pictorial view of project	Job Execution by Printer in Hours	Job Execution by Traditional process in Hours
<b>3D Printing Job.</b>				
1	Cor 45 Deg (Medical equipment) in ABS material; Size = x-45.179mm, y-44.5mm, z-60.78mm.		1 Hours 40 minutes	Mould+ Sample +Inspection+ Final Sample = Min 48 hours
2	Bottle ; b) Cap1; c) Cap2 and d) Lid in ABS Material; Size= X-24.95mm width, Z -25mm width, Y-83.045 mm height.		4 Hours 40 Minutes	Mould+ Sample +Inspection+ Final Sample = Min 60 hours
3	Electric insulator part in ABS material; Size= X-213mm and Y-96mm, z-90mm.		10 Hours	Mould+ Sample +Inspection+ Final Sample = 72 hours

# 1. Reverse Engineering and 3D Printing Projects

## 3D Printing Prototypes

ABS Electric insulator, ABS Cor 45 Deg Bottle, Cap1, Cap2 and Lid

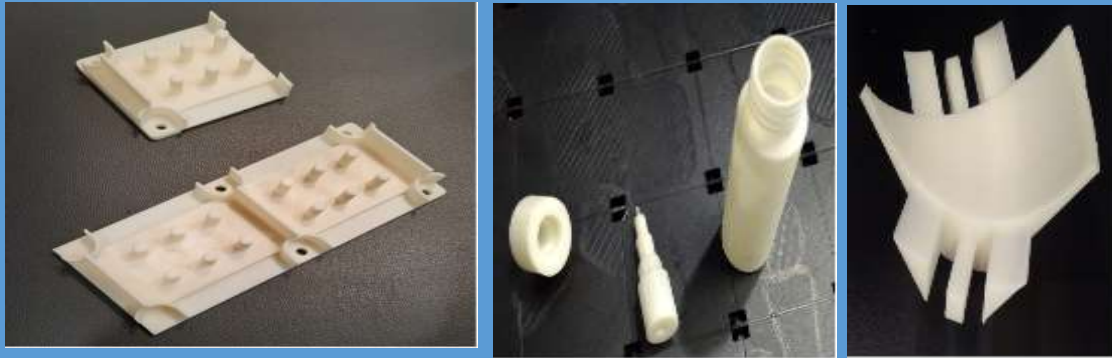

## 3D Modelling and Drafting support

Ni-Hard Block , Valve Cylinder Assembly, Piston Rod Assembly, Gears, Mud Gun, Manhole Frames and covers, Small and large Gratings, Lever for Bleeder valve.

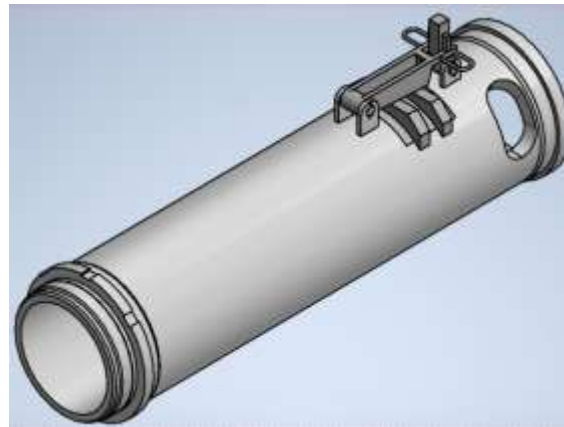
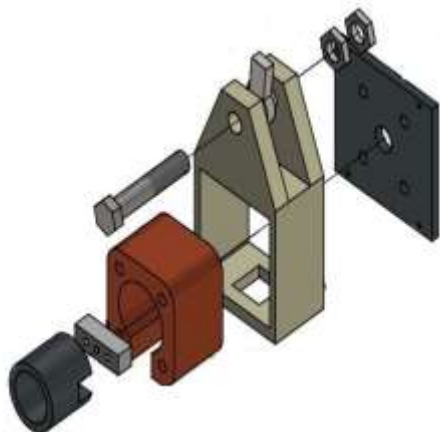
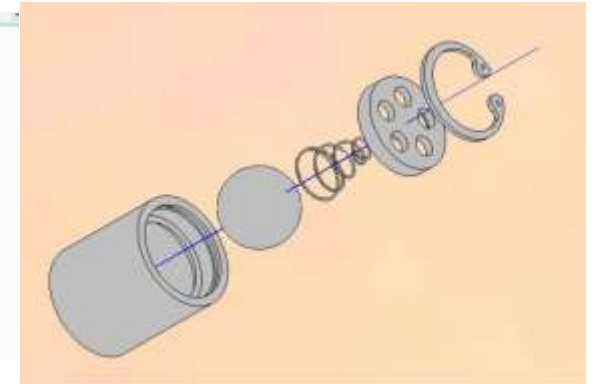
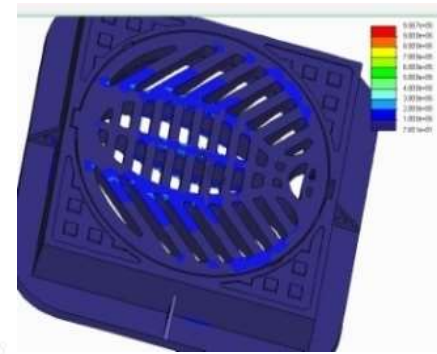



## TIE- UPS - TESTING, CALIBRATION AND INSPECTION LABS

SL. No.	Name of Laboratory	Services	Contact Details	Region	Address
1	Chennai Mettlex Lab Private Limited, Chennai	Testing	V. Dharani Kumar, Mob : 09094046912, kumar@mettlexlab.com	Southern	Jothi Complex, No. 83, MKN Road, Guindy, Chennai - 600 032
2	SGS India Pvt. Ltd., Kolkata	Inspection, Testing & Certifications	Mr. Arup Jana, Head- Certification Sales, <a href="mailto:arup.jana@sgs.com">arup.jana@sgs.com</a> , 9433220320 Cijoy Cleatus, Phone - 91-044-66081832 Mobile - 91-9962048688, E-mail: <a href="mailto:cijoy.p@sgs.com">cijoy.p@sgs.com</a>	PAN India	SGS House 4B, Adi Shankaracharya Marg, Vikhroli (West)
3	ANULAB INDUSTRIAL TESTING & ANALYTICAL LABORATORIES, UP	Inspection & Testing	Er. Mohit Gupta, Mobile: +91-9837052093 Email: <a href="mailto:research@anulab.org">research@anulab.org</a>	Northern	212 km Milestone, NH-2, Agra Kanpur Road, Nagla Rambaksh, Post: Dhaurra, Tehsil: Etmadpur, Agra-283202, Uttar Pradesh, India
4	M/s. TCR Engineering Services Pvt. Ltd., Mumbai	Inspection & Testing	Rohit Bafna, <a href="mailto:rohit@tceng.com">rohit@tceng.com</a> , +91 50 785 8901, +91 9833530400	Western	VKB House, EL-182, MIDC-TTC, Electronic Zone, Mahape, Navi Mumbai-400 710 Maharashtra, India
5	National Research & Technology Consortium (NRTC), HP	Calibration, inspection & Testing	Dr. Suresh C Attri, Officer in-charge, <a href="mailto:sattri-en-v-hp@nic.in">sattri-en-v-hp@nic.in</a> , 0177-2659608/ Dr. Kiran Gupta, Principal Scientific Officer, <a href="mailto:guptakiran5@yahoo.co.in">guptakiran5@yahoo.co.in</a> , 01792-234107	Northern	Department of Industries Complex, Sector-1, Parwanoo, Solan-173220, HP
6	Excel Surveyors Pvt. Ltd.	Inspection, Testing & Calibration	Mr. Sudip Kr. Chanda, MD, <a href="mailto:sudip@excelsurveyor.com">sudip@excelsurveyor.com</a> , 9825121860 Mrs. Sanchita Bhattacharya, <a href="mailto:sanchita.cms@gmail.com">sanchita.cms@gmail.com</a> , 9830278995	Eastern	1/6 Fakir Ghosh Lane, Baranagar, Kolkata - 700108

## TIE- UPs - CERTIFICATION BODIES

SL. No	Name of Certification Body	Services	Contact Details	Region
1	Swisscert	ISO 9001, ISO 14001, ISO 45001	R. N. Verma , 9836030666, <a href="mailto:rnverma52@gmail.com">rnverma52@gmail.com</a> Mr. Vishal Kumar, <a href="mailto:info@swisoindia.com">info@swisoindia.com</a> , 9811441507	PAN India
2	TUV SUD	ISO 9001, ISO 14001, ISO 45001	Supravat Mondal Email- <a href="mailto:Supravat.Mondal@tuvsud.com">Supravat.Mondal@tuvsud.com</a> Mobile- +91 9748422511 Kaushik Paul, Email-Kaushik.Paul@tuvsud.com, Mobile-919432372453	PAN India
3	URS	ISO 9001, ISO 14001, ISO 45001	Mr Ankur Sanghal Email Address :- <a href="mailto:ankur@ursindia.com">ankur@ursindia.com</a> Mobile No :- 9350169159 ( Head Office, Noida) Aloke Sanyal mob. – 9830122117, 8420105764, <a href="mailto:kolkata@ursindia.com">kolkata@ursindia.com</a> (Kolkata Contact)	PAN India
4	SGS India Private Limited	ISO 9001, ISO 14001, ISO 45001	Mr. Arup Jana, Head- Certification Sales, <a href="mailto:arup.jana@sgs.com">arup.jana@sgs.com</a> , 9433220320	Pan India

## Panel of Technical Subject Experts

S. N.	NAME OF EXPERT	FREELANCE/ORGANIZATION	LOCATION	AREAS OF EXPERTISE
01.	Mr. Devasis Paul	IIW	Kolkata	Automation in Arc Welding
02.	Mr. Jignesh Patel	IIW	Ahmadabad	Quality Control and Inspection of Fabricated Structures
03.	Mr. T. Ravi Kumar	IIW	Bengaluru	Destructive and Nondestructive Testing of welded Structures
04.	Mr. Jayanta Basu	Techo Enterprise	Kolkata	Design, Cutting tools, Machine and machine tools
05.	Dr. Anjan Prodhan	Freelance – Ex- NML	Kolkata	Process Metallurgy
06.	Mr. S. Gabriel Vasanthakumaran	Lawrence & Mayo	Kolkata	GNSS/Drones/Terrestrial Scanners
07.	Mr. Parijat Mukherjee	Freelance – Ex- SGS	Kolkata	Inspection and Quality Assurance
08.	Dr. Nilanjan Mallik	IIT BHU	Banaras	Mechatronics, Nanotechnology
09.	Dr. Dehi Pada Mondal	CSIR-AMPRI	Bhopal	Aluminum alloys, casting, deformation, heat treatment
10.	Mr. S P Singh	CEIL	Mumbai	Quality Control, Inspection & Certification
11.	Dr. Sanjai Kumar Singh Rathore	Freelance- Ex- CSIR- AMPRI	Bhopal	Natural Resource & IP Management, Competency Mapping
12.	Mr. Subhasis Datta	Freelance- Ex- M N Dastur	Kolkata	Project & Risk Management, Project Management Training
13.	Mr. Girish Sethi	TERI	Delhi	Energy Audit
14.	Mr. Prosanto Pal	TERI	Delhi	Green Energy & Conservation of Energy
15.	Mr. D. Karthikeyan	Freelance	Bengaluru	New Product Development Detailed Engineering Design DFMA/Design for Excellence

## 2. Training/Seminars - 2019-2020

**Number of Seminars/Training Programs – 43**  
**Number of Participants – 993**

SL.NO.	FOCUSED AREAS	SOME IMPORTANT TOPICS
1	Mechanical	<ul style="list-style-type: none"> <li>•Smart and alternative materials</li> <li>•Alternative Material Science and its application</li> <li>•New processes for Foundry</li> <li>•Pumps &amp; Valves, Precision Machinery, Industrial Machinery, Electrical Machinery</li> <li>•Transition from 2D to 3D Design</li> </ul>
2	Industry 4.0	<ul style="list-style-type: none"> <li>•Additive Manufacturing</li> <li>•Reverse Engineering</li> <li>•Benefits of simulation software for foundries</li> <li>•Industry evinced interest for Centre of Excellence</li> </ul>
3	Japanese Management Techniques	<ul style="list-style-type: none"> <li>•Six Sigma</li> <li>•Process Capability Analysis</li> </ul>
4	Trade promotions	<ul style="list-style-type: none"> <li>•Intellectual Property Rights (IPRs)</li> <li>• Foreign Trade Policy- Manual v/s. Digitization - Facilities and Benefits</li> <li>•Efficient Logistics Management, Online Digital Platform &amp; Smart Financing</li> </ul>

## 2. Training/Webinars - 2020-2021

**Number of Seminars/Training Programs – 20**  
**Number of Participants – 1144**

SL.NO.	FOCUSED AREAS	SOME IMPORTANT TOPICS
1	Mechanical	<ul style="list-style-type: none"> <li>•Welding Technology and the role of International Certification of Manufacturers</li> <li>•Advanced Welding in Foundry and Casting Industries</li> <li>•Automated manufacturing operation on Casting &amp; Forging Industries.</li> <li>• New product Development by re-cycling Casting Slag, Alternate Manhole Cover</li> <li>•Micro Electro Mechanical System (MEMS) sensors for industrial applications</li> </ul>
2	Industry 4.0	<ul style="list-style-type: none"> <li>•Opportunities in Additive Manufacturing for Indian Industries Post Lockdown 4.0</li> <li>•Industrial Internet of Things (IIOT) and its relevance in Digital manufacturing</li> <li>•Smart Foundries through IIoT</li> <li>•3D Scanning Designing &amp; Printing -A tool for reverse engineering</li> </ul>
3	Japanese Management Techniques	<ul style="list-style-type: none"> <li>•Gemba Walk-A lean Management</li> <li>• Introducing good manufacturing practice by solving work related problems</li> <li>•Waste Management at Factory Premises during COVID-19</li> <li>•Increasing factory Productivity through "Overall Equipment Effectiveness (OEE)"</li> </ul>
4	Trade promotions	<ul style="list-style-type: none"> <li>•Covid 19 Related Technologies developed by CSIR-CMERI where MSMEs can associated and Import substitution where CSIR-CMERI can play a vital role.</li> </ul>



## 2. Training/Webinars - 2021-2022

**Number of Seminars/Training Programs – 23**  
**Number of Participants – 741**

SL.NO.	FOCUSED AREAS	SOME IMPORTANT TOPICS
1	Mechanical	<ul style="list-style-type: none"> <li>•Manhole cover production from Casting slag</li> <li>•GD&amp;T and CMM</li> <li>•Cold Metal Transfer Welding Technology and its Benefits</li> <li>• American Welding Society representation, dimensioning and Interpretation</li> <li>•Innovative Tooling Solutions for Productivity Excellence</li> </ul>
2	Green Technology	<ul style="list-style-type: none"> <li>•Carbon Footprint</li> <li>•Energy Conservation, Management and Audit of Electrical &amp; Thermal Utilities</li> </ul>
3	Industry 4.0	<ul style="list-style-type: none"> <li>•3D Printing and Scanning</li> </ul>
4	Japanese Management Techniques	<ul style="list-style-type: none"> <li>•Scientific Meditation to revitalize the Employee morale and confidence</li> <li>• Production Process control and Audit Techniques to achieve Business Excellence</li> <li>•5S of Housekeeping and Implementation</li> <li>•Kaizen - Productivity Improvement</li> </ul>
5	Trade promotions	<ul style="list-style-type: none"> <li>•Significance of Product Certification in Exports of Castings</li> <li>•Achieving export excellence by adhering to BS EN 124 Standard</li> </ul>

## 2. Training/Webinars - 2022-2023

**Number of Seminars/Training Programs - 10**  
**Number of Participants - 864**

SL.NO.	FOCUSED AREAS	SOME IMPORTANT TOPICS
1	Green Technology	<ul style="list-style-type: none"> <li>• Green technology and practices for foundry and steel re-rolling industries</li> </ul>
2	Industry 4.0	<ul style="list-style-type: none"> <li>• Drone- manufacturing for various application and operational training</li> <li>• Industrial sensors for transport and manufacturing sectors</li> </ul>
3	Technology Development	<ul style="list-style-type: none"> <li>• Up-gradation of Technology in Casting Industry</li> </ul>

### 3. Facilitating MSMEs through Consulting and Advisory services

- ✧ Technology Centre of EEPIC India has collaborated with the **Scientific and Industrial Testing and Research Centre (SiTarc), Coimbatore** for development of **SMART PUMP** which is a high speed permanent magnet pumpset, capable of operating at 4000 rpm.
- ❖ Technology Centre of EEPIC INDIA along with **CSIR-CMERI** and **SIEMA-Coimbatore** had collaborated for the development of **Smart Positioner for the Industrial Valves** with below status:
  - ∨ Based on the 6th Tech Meet held on 06 July 2018, Product development cluster formation would be revisited by MSME participants provided an option for scale down version of the project proposal for Smart Positioner development of Industrial Valves is provided by CSIR-CMERI.
  - CSIR-CMERI subsequently shared a revised PD-DPR by July 2019 (from an earlier budget of 1799 lakhs to 1193 lakhs by excluding the development cost of piezo actuator-based smart positioner) for the PD Cluster development.
  - MSME participants who showed interest in the project are spread over different states and were quite uncomfortable in having an Infrastructure CFC setup at Coimbatore.
- 📁 Technology Centre collaborated with ERDA and other stakeholders for the development of **5 HP, IE4 class electric motors** for its usage in the Electric Vehicles segment and other possible applications. Meetings were held in Mumbai & Vadodara. The DPR is being finalized and submitted by ERDA.

### 3. Facilitating MSMEs through Consulting and Advisory services

- ❖ The Tech Centre in collaboration with **CSIR-AMPRI, Bhopal** has developed **Tiles out of Casting Slag** which may be used for **Industrial and domestic flooring**. These tiles are fracture resistance, tough and have very good load bearing capacity. They can be vitrified/glazed.
- ❖ **CSIR-AMPRI, Bhopal** in liaison with EEPIC India Technology Centre has also developed **Manhole cover** (instead of Cast Iron) with **Composite material (Aluminium metal composites)** which has good tensile strength, abrasive, corrosion and impact resistance as well as 30 % lighter than Cast iron products.
- ❖ EEPIC INDIA in collaboration with **CSIR – CMERI** has designed a multi-skilling hands-on training module in CNC and Conventional Machining operations for **Skill Development** for MSMEs in their facility .
- ❖ EEPIC Tech Centre in collaboration with **ISI, Kolkata** has designed a 5 days course on 6 Sigma for Skill development for MSMEs in our facility.
- ❖ Tech Centre in collaboration with **CSIR-CMERI** experts is also in the process of developing an **AI & ML based automated manufacturing operations (Shop floor management)** which can be controlled remotely.
- ❖ EEPIC India Tech Centre in collaboration with **CSIR-CMERI**, Durgapur is trying to share certain business opportunities to EEPIC MSMEs members for some fabrication jobs under Solid Waste Management projects of CMERI.
- ❖ **EEPC IPR Cell** has assisted M/s Appidi Technologies, Hyderabad (EEPC India member) during their **Technology transfer project** with a Korean Company.

## Intellectual Property Right Cell.

Tech Centre IPR related facilities and services offered –

1. Trade marks: Brand names, trade names.
2. Copyrights: Literary, musical, artistic and dramatic works.
3. Patents: Novel inventions in field of technology and science.
4. Designs: Industrial designs.
5. Legal and commercial agreement for Technology Development and Transfer.
6. Due diligence and agreement for collaboration.





## EEPC INDIA students interface : Engineering students made industry-ready

### Training Structure (Online/Classroom)

- ▶ Module based training of 2 hrs each twice/thrice a week at Skill Development Centre - EEPC India, Kolkata through Interactive Spark Board (Cisco)
- ▶ Total training hours :- 21 hours (10 modules each) including Project and Demo
- ▶ Expert Faculty + Practical training by Design & Development Department, EEPC India Technology Centre, Kolkata.
- ▶ Project per batch of 7 students
- ▶ Certification after examination and project submission - evaluation by Panel
- ▶ Co-Certification by EEPC INDIA and the Institute
- ▶ CVs of Certified students will be posted in the EEPC INDIA Tech Centre portal.



## EEPC INDIA students interface : Engineering students made industry-ready

### Mechanical Design

- Design for Manufacturing, Assembly concepts (DFMA)
- Plastic Product Design
- Design of Plastic Snap Fits
- Sheet Metal Design
- Design for 3D printing
- Engineering drawings
- Material Science
- Heat Treatment
- Training on CAD software

### Quality Tools

- 7 QC Tools
- Root Cause Analysis
- Process Capability
- Quality Function Deployment (QFD)
- Gage R&R Analysis
- Kaizen tools

### Lean Manufacturing

- Overall Equipment Equipment (OEE)
- 5S – House keeping
- Just-in-Time (JIT)
- Lean Wastes
- Poka-Yoke (Error Proofing)
- Value Stream Mapping (VSM)
- Total Productive Maintenance (TPM)
- Jidoka (Autonomation)
- Key Performance Indicators (KPIs)
- Kaizen
- Gemba Walk

### Six Sigma

- DMAIC methodology – Yellow Belt BoK
- Define phase** Fundamentals, Metrics, Project charter
- Measure Phase** Process Definition, Statistics MSA, Cp, Cpk studies
- Analyze Phase** Variations, Hypothesis Testing
- Improve Phase** Regression Analysis
- Control Phase** SPC and Control plans

### New Product Dev. (NPD)

- NPD Phases
- Deliverables by team
- Product Characteristics
- Manufacturing Characteristics
- NPD tools
- Stage gate reviews
- Project complexity
- Financial Assessment
- NPD Deliverables

### Additive Manufacturing

- Module -1:** Introduction to Additive Manufacturing and Industry 4.0 (Theory)
- Module -2:** Introduction to 3D printing (Theory)
- Module -3:** Introduction to Fused Deposition Modelling (FDM) Technology (Theory)
- Module -4:** Reverse Engineering Techniques (Theory)
- Module -5:** Training on 3D printing Software (Practical)
- Module -6:** Usage of 3D Scanners (Practical)
- Module -7:** Project and Certification (Practical)
- Module -8:** Interview Preparation-Resume Writing (Theory & Practical)
- Module -9:** Interview Preparation-Group Discussion (Theory & Practical)
- Module -10:** Interview Preparation-Successful Interviews (Theory & Practical)

Competency Development Courses

## 6. EEPCINDIA students interface

### Present Scenario:

- Curriculum in Engineering Colleges /Technical Institutes not up-to-date with concepts of Industry 4.0
- Students unaware of Additive Technology, Industrial IoT at Diploma / UG level etc.
- Lack of trained faculty on emerging topics, lack of Infrastructure or lack of initiative.

### Outcome:

- Companies visiting campuses for recruitment expect reasonable knowledge in these latest concepts.
- Such students lag behind in their race to secure job in good engineering companies.

### Objective:

- In view of the present job market and competitiveness, it is essential for the institutes to incorporate a short course wherein concept of Industry 4.0 especially subjects like Additive Technology to make their students employable and fit for the job market.
- EEPC India Technology Centre at Kolkata will collaborate with such Institutes through a techno-commercial agreement (MOU) where student may undertake a short course on 3 D Designing & Printing at the facility in Kolkata.

## 7. Membership & Benefits

Membership type	Category	Annual Subscription Fee	Benefits
Organizational Membership	EEPC-India members	Rs. 5,000	<ul style="list-style-type: none"> <li>• <b>Reverse engineering &amp; Additive Manufacturing Facility at Tech Centre, Kolkata – Capabilities and Capacities.</b></li> <li>• <b>Training and Seminars:</b> Best Industry Practices e.g. Six Sigma, Lean manufacturing, 5S house-keeping , Quality control circles, KAIZEN, TPM, etc. and dissemination of technical inputs on latest technology.</li> <li>• <b>Advisory and Consultancy services:</b> - Facilitating Technical troubleshooting, process improvement/development, product development, Re-use through recycling, waste.</li> <li>• <b>Testing, Calibration and Inspection:</b> Facilitate by suitable tie-up with NABL accredited labs across India at concessional rate.</li> <li>• <b>Certification of Standards:</b> viz. ISO, CE marking, etc. by standardize agencies at concessional rate.</li> <li>• <b>IPR activities:</b> Patenting of products, copyrights, assessment and formulating collaborative agreements through its <b>Intellectual Property Right Cell.</b></li> <li>• <b>Knowledge and information dissemination</b> through website <a href="http://www.techcenter.eepcindia.com">www.techcenter.eepcindia.com</a> , in-house magazine ie2 and Tech Centre E-News Letter.</li> <li>• <b>EEPCINDIA students interface</b> : For Junior Engineers and fresh Engineering students made industry-ready.</li> <li>• <b>Tech Centre Membership &amp; Benefits</b>–Organizational (EEPC and Non-EEPC) and Individual (Technocrats and Students).</li> <li>• Panel of Technical Subject Experts are available to impart specialized and expertise knowledge, solutions and consultancy through the concept of “<b>Multi-specialty Techno-clinic</b>” .</li> <li>• Implementation of <b>Energy conservation &amp; Energy Audit</b> in Engineering Industries in association with TERI, New Delhi.</li> </ul>
	Non-EEPC-India members	Rs. 7,500	
Individual Membership	Technocrat (Minimum-trade certificate from ITI)	Rs. 2,500	
	Students (B.E/ B.Tech Onwards) / PhD Scholar	Rs. 1,200	

thank you!

